



A series Electric Tow Tractor

with capacities of 4,500/9,000/13,500lbs

The World of Hangcha



A series Electric Tow Tractor

As for A series of tractors, the advanced AC drive control technology is adopted for the complete tractor. The tractor has excellent performance, can be operated comfortably, is safe and reliable, has low maintenance cost and is the high-efficiency tool for resolving material transport among different zones for the workshops, flow lines and large factories.

**Simple/
Solid/
Smart**



Appearance

- / The professional appearance industrial design is adopted. The complete tractor has smooth lines, presents the dynamics. The ergonomics is fully considered to meet the latest appearance design fashion.
- / The steel plate stamping and injection moulding technology is used extensively, the tractor is firm and durable and can meet the environmental protection requirements.

High performance

- / For the stand-up driving tractor, the electronic power steering is taken as the standard configuration to achieve easier and more flexible operation and control.
- / The AC traction motor features excellent acceleration performance, outstanding climbing ability, low heat emission, and is brushless, and maintenance-free.
- / The advanced AC control system realizes accurate and stable control, and higher efficiency.
- / The CANBUS bus structure makes communication of the entire machine faster and more reliable.

Comfortability

- / LED headlight is taken as the standard configuration; the headlight has good appearance and offers bright light.
- / Multifunctional instrument is taken as the standard configuration, has such many functions as speed selection and so on, and can clearly display different information of the tractor.
- / The suspension structure is adopted for the front axle and rear axle to greatly enhance the operator's comfortability during tractor traveling.
- / USB charging port and mobile phone placement slot are taken as the standard configuration for conveniently charging the mobile phone and providing convenience for the operator.
- / The advancing and retreating buttons are provided at the tail of the tractor body, so that the tractor can be operated to move forward and backward while manipulating the traction device and it does not need to frequently go aboard and get off during operation.



Reliable LED lighting



Battery side roll out is taken as the standard configuration in order to easily and fast replace the battery



Modern outline design with LCD instrument and USB charging port



Electrical Park Brake (EPB) system



The locking device of the battery is provided with the safety protection function. Only if the locking device is rotated in place, the tractor can travel



Reliability

- / The three-support-point and low-gravity-center design is adopted. The high-strength steel plate framed structure is adopted for the chassis. The tractor has long service life.
- / All of wires and cables are provided with reliable protection, and the electrical system reliability is greatly improved.
- / Such important components as switches, connector clips, instruments and so on are imported from foreign countries, and have excellent performance and reliable quality.

Maintenance

- / The brushless, maintenance-free AC motor reduces operation cost significantly.
- / The meter integrating battery indicator, timer, and fault self-diagnosis is convenient for maintenance.
- / The front bottom plate and rear cover plate can be easily dismantled, and such parts and components as braking pump, electric control device, motor and so on can be conveniently maintained.

Safety

- / Turning slow down function is taken as the standard configuration to guarantee stable and safe turning of the tractor.
- / The Electrical Park Brake (EPB) is taken as standard configuration to achieve greater convenience and safety.
- / The safety pedal is taken as standard configuration. The other operations can be made only if the pedal is trampled. In this way, safety is enhanced.

Options

- / Fully-enclosed cabin
- / Semi-closed cabin
- / Suspension seat
- / Left and right mirror
- / Alarm lamp
- / Solid tyre
- / Big capacity battery



Standard specification

- / AC traction motor
- / Automatic deceleration at turns
- / Key switch
- / USB charging port
- / LED headlight
- / LED tail light
- / Battery side extraction
- / Creep speed function
- / Safety pedal
- / Emergency power-off switch
- / Electrical Park Brake (EPB) system
- / Traction device
- / Horn
- / Inching switch



A series Electric Tow Tractor specification

Distinguishing mark	1.1	Manufacturer	HANGCHA GROUP CO.,LTD.			
			HCFA Model	QDD2	QDD4	QDD6
	1.2	Manufacturer's type designation	QDD20-AC1	QDD40-AC1	QDD60-AC1	
	1.3	Drive: electric (battery or mains), diesel, petrol, fuel gas	Electric	Electric	Electric	
	1.4	Operator type: hand, pedestrian, standing, seated, order-picker	Sit down	Sit down	Sit down	
	1.5	Rated capacity/rated load	Q(lb/t)	4500/2	9000/4	13500/6
	1.7	Rated drawbar pull	F(lbf/N)	112.5/500	225/1000	337.5/1500
	1.9	Wheelbase	y(in/mm)	45.1/1145	51.4/1305	51.4/1305
Weights	2.1	Service Weight (Including battery)	lb/kg	1938/880	2379/1080	2533/1150
Wheels, Tyres	3.1	Tyres: solid rubber, superelastic, pneumatic, polyurethane		Pneumatic	Pneumatic	Pneumatic
	3.2	Tyre size, front		3.50-5-6PR	3.50-5-6PR	3.50-5-6PR
	3.3	Tyre size, rear		4.00-8-6PR	4.00-8-6PR	4.00-8-6PR
	3.5	Wheels, number front / rear (x = driven wheels)		1/2x	2/2x	2/2x
	3.6	Tread, front	b10 (in/mm)	0	9.8/250	9.8/250
	3.7	Tread, rear	b11 (in/mm)	30.3/770	30.3/770	30.3/770
	Dimensions	4.1.2	Coupling height	h10 (in/mm)	14.4/365.10.5/267	14.4/365.10.5/267
4.1.7		Overhang	ls(in/mm)	9.6/245	9.6/245	9.6/245
4.1.9		Overall length	l1 (in/mm)	66.3/1684	72.6/1844	72.6/1844
4.2.1		Overall width	b1(in/mm)	35.4/900	35.4/900	35.4/900
4.3.2		Ground clearance, centre of wheelbase	m2 (in/mm)	3.9/100	3.9/100	3.9/100
4.3.5		Turning radius	Wa (in/mm)	63/1600	69.4/1763	69.4/1763
Performance	5.1	Travel speed, laden/unladen	m/ph km/h	3.7/8.1 6/13	3.7/8.1 6/13	3.7/8.1 6/13
	5.6	Max. Drawbar pull	lbf/N	450/2000	900/4000	1012.5/4500
	5.7	Gradeability, laden/unladen	%	5/25	5/25	5/25
Electric engine	6.1	Drive motor rating S2 60 min	hp/kw	2.61/1.95	5.74/4.28	5.74/4.28
	6.4	Battery voltage, nominal capacity K5	V/Ah	48/165	48/210	48/275
		Battery voltage, nominal capacity K5 (Opt.)	V/Ah	48/180~210	48/220~350	48/280~350
	Electric control model		CURTIS	CURTIS	CURTIS	

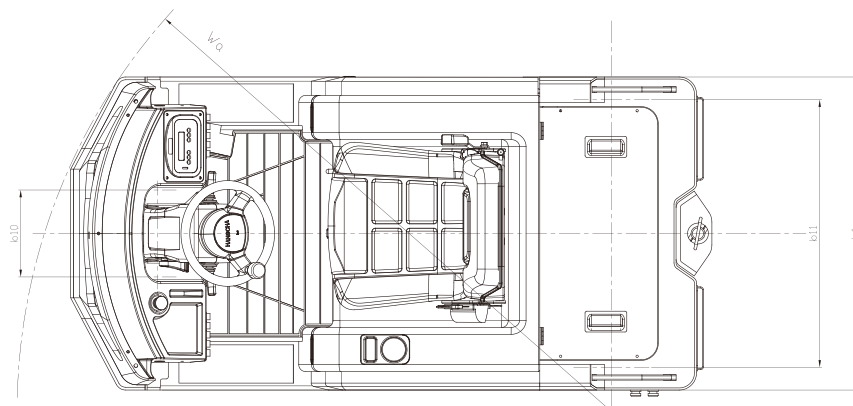
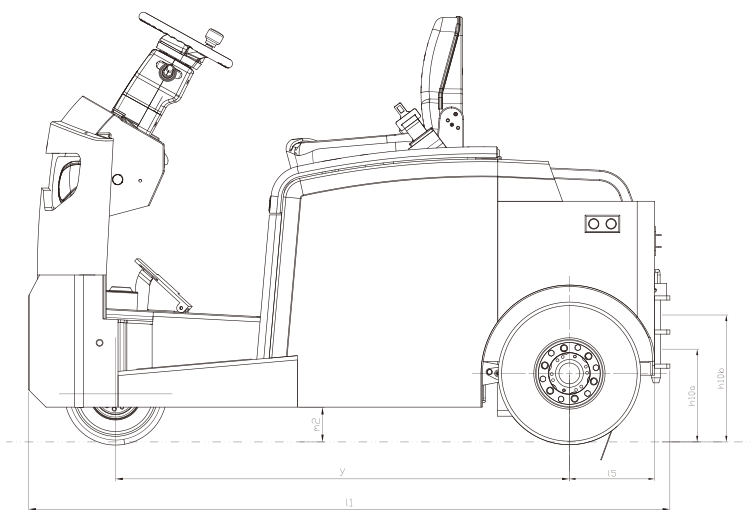



A60

HANGCHA

8

8

8

P02

5



HANGCHA FORKLIFT CANADA INC.

Company address:

6-980 Rue Valois, Vaudreuil-Dorion,
QC, J7V 8P2, Canada

Toll Free: 877-319-HCFC (4232)

Landline: 450-319-HCFC

info@hcforkliftcanada.com
www.hcforkliftcanada.com



ISO14001:2015



ISO9001:2015



Follow us on
Facebook



Follow us on
YouTube



Follow us on
WeChat



Download "Hangcha
Forklift" App



HANGCHA GROUP CO., LTD. reserves the right to make any changes without notice concerning colors, equipment, or specifications detailed in this brochure, or to discontinue individual models. The colors of trucks, delivered may differ slightly from those in brochures.