



A Series 3-Wheel Electric Forklift

with capacities of 3,000 to 4,000lbs

The World of Hangcha



Move freely, lift freely

The newest generation A series 3-Wheel electric counterbalance truck is new product of HANGCHA. The totally new designed outline, safety, comfortability and reliability are fully improved, and the whole truck's performance is also improved.





A20 AC-POWER

A20 AC-POWER

HANGCHA



Appearance

- / Compact design meets the limited space operation requirement. Eyeball catching designed smooth outline and metal material applied for exposed parts, all provide robust construction of the A series three-pivot electric counterbalance forklift truck.

Maneuverability

- / Front dual separated driving motors can realize the wheels forward or backward independently, the small turning radius is suitable for narrow channel; Imported reducer, high power driving motor provides a reliable and strong performance.

High Efficiency

- / High power pump motor and low noise gear pump, both improve the lifting speed and work efficiency.
- / Regenerative braking during deceleration is more energy saving and effectively.

Comfort

- / Thanks to the new designed adjustable levers, the operator can work more comfortable. New designed dashboard is easy to see and provides friendly human-computer interaction and with running hours, self diagnosis functions and the battery power show.
- / Both the steering column and seat can be adjusted easily, every operator can find the best driving position.
- / Low vibration and suspension seat reduce the driver's fatigue.

Stability

- / Sinking type battery layout provides good stability especially during cornering.
- / The soft landing system protects the forks from dashing against the ground.

Safety

- / Emergency switch is standard specification which meets the Euro safety regulation.
- / Both electronics and hydraulic system are equipped with overloading protection system.
- / Driving speed is automatically reduction during cornering.

Maintenance

- / Full opened battery cover is easy for battery service and changing.
- / The service engineer can remove the front floor board without any tool, it is convenient for the maintenance.

Advance

- / World famous controller, connectors, battery plug and emergency switch are applied to ensure the reliability of the performance and provides easy service.
- / High frequency MOSFET integrated control system provides accurate control of travelling, lifting and better adjustable performance that better matches with the motor. No roll-back on ramp is also provided thanks to MOSFET controller. Motor brake is for regenerative braking during deceleration, direction changing, and downward slope.



The 36v system and the 48v system can be switched by Changing the battery and switching the meter mode.

Standard Specification

- / High efficiency AC driving motor
- / Multi-functions instrument
- / Front dual driving motors
- / Rubber floor mat
- / Smooth Cushion Tyre
- / Emergency disconnect switch
- / LED headlight
- / Rear combination LED light
- / Panoramic rearview mirror (in the middle position of the overhead guard)
- / 118.1 inch duplex wide view mast
- / Adjustable steering column
- / Full electronic controlled travelling, lifting and steering
- / Horn and reversing buzzer
- / CAN-BUS system
- / Low noise gear pump (Brand: Shimadzu, Made in Japan)
- / Full hydraulic steering
- / Soft landing system
- / Non suspension seat: Grammer GS12 with switch
- / ZF reducer and SCHABMULLER traveling motor
- / CURTIS controller

Options

- / 3rd or 4th hydraulic function
- / 98.4~177.2 inch duplex mast
- / 169.3~255.9 inch triplex mast
- / Rear working LED light
- / Reversing assist grip with horn button
- / Integrated sidsifter
- / Other attachments
- / Other dimension forks
- / Special carriage and backrest
- / Big capacity battery
- / Non-marking tyre
- / Battery charger
- / Battery side extraction
- / Fingertip control on the adjustable armrest
- / Freezer
- / Suspension seat
- / Full closed cabin
- / Traction tyres
- / Blue spot light
- / OPS system



Front dual separated motors



Panoramic rearview mirror



Cover can be easily opened by adjusting the levels forward



The small turning radius is suitable for narrow aisle

4,000lb Mast

| Type | Model | Lifting height in(mm) | Overall height | | | | Free lifting height | | Front Overhang in(mm) | Tilting range | | Capacity | |
|-----------------------|-------|--------------------------|-------------------|-------------------------|----------------------------|-------------------------|----------------------------|----------------|--------------------------|-----------------|--------------------------------|----------|--|
| | | | Lowered in(mm) | Extended | | With backrest in(mm) | Without backrest in(mm) | Forward deg | | Backward deg | Load capacity at 24 in (600mm) | | |
| | | | | With backrest in(mm) | Without backrest in(mm) | | | | | | 4000lb lb(kg) | | |
| Duplex wide view mast | M250 | 98.4(2500) | 68.1(1730) | 136.0(3455) | 119.4(3033) | 5.7(145) | 5.7(145) | 15.0(380) | 5.5 | 6 | 4000(1810) | | |
| | M270 | 106.3(2700) | 72.0(1830) | 143.9(3655) | 127.3(3233) | 5.7(145) | 5.7(145) | 15.0(380) | 5.5 | 6 | 4000(1810) | | |
| | M300 | 118.1(3000) | 78.0(1980) | 155.7(3955) | 139.1(3533) | 5.7(145) | 5.7(145) | 15.0(380) | 5.5 | 6 | 4000(1810) | | |
| | M330 | 129.9(3300) | 83.9(2130) | 167.5(4255) | 150.9(3833) | 5.7(145) | 5.7(145) | 15.0(380) | 5.5 | 6 | 4000(1810) | | |
| | M350 | 137.8(3500) | 87.8(2230) | 175.4(4455) | 158.8(4033) | 5.7(145) | 5.7(145) | 15.0(380) | 5.5 | 6 | 4000(1810) | | |
| | M360 | 141.7(3600) | 91.7(2330) | 179.3(4555) | 162.7(4133) | 5.7(145) | 5.7(145) | 15.0(380) | 5.5 | 6 | 4000(1810) | | |
| | M400 | 157.5(4000) | 101.6(2580) | 195.1(4955) | 178.5(4533) | 5.7(145) | 5.7(145) | 15.0(380) | 3.5 | 5 | 4000(1810) | | |
| | M430 | 169.3(4300) | 107.5(2730) | 206.9(5255) | 190.3(4833) | 5.7(145) | 5.7(145) | 15.0(380) | 3.5 | 5 | 3900(1770) | | |
| | M450 | 177.2(4500) | 111.4(2830) | 214.8(5455) | 198.1(5033) | 5.7(145) | 5.7(145) | 15.0(380) | 3.5 | 5 | 3800(1720) | | |
| | M450 | 98.4(2500) | 68.7(1745) | 135.6(3445) | 120.4(3059) | 31.5(800) | 46.7(1186) | 15.2(386) | 5.5 | 6 | 4000(1810) | | |
| Duplex full-free mast | U250 | 98.4(2500) | 68.7(1745) | 135.6(3445) | 120.4(3059) | 31.5(800) | 46.7(1186) | 15.2(386) | 5.5 | 6 | 4000(1810) | | |
| | U270 | 106.3(2700) | 72.6(1845) | 143.5(3645) | 128.3(3259) | 35.4(900) | 50.6(1286) | 15.2(386) | 5.5 | 6 | 4000(1810) | | |
| | U300 | 118.1(3000) | 78.5(1995) | 155.3(3945) | 140.1(3559) | 41.3(1050) | 56.5(1436) | 15.2(386) | 5.5 | 6 | 4000(1810) | | |
| | U330 | 129.9(3300) | 84.4(2145) | 167.1(4245) | 151.9(3859) | 47.2(1200) | 62.4(1586) | 15.2(386) | 5.5 | 6 | 4000(1810) | | |
| | U350 | 137.8(3500) | 88.4(2245) | 175.0(4445) | 159.8(4059) | 51.2(1300) | 66.4(1686) | 15.2(386) | 5.5 | 6 | 4000(1810) | | |
| | U360 | 141.7(3600) | 90.4(2295) | 178.9(4545) | 163.7(4159) | 53.1(1350) | 68.3(1736) | 15.2(386) | 5.5 | 6 | 4000(1810) | | |
| | U400 | 157.5(4000) | 100.2(2545) | 194.7(4945) | 179.5(4559) | 63.0(1600) | 78.2(1986) | 15.2(386) | 3.5 | 5 | 4000(1810) | | |
| | U400 | 157.5(4000) | 74.0(1880) | 198.7(5046) | 182.0(4622) | 32.8(834) | 49.5(1258) | 15.6(395) | 3.5 | 5 | 4000(1810) | | |
| | N430 | 169.3(4300) | 78.0(1980) | 210.5(5346) | 193.8(4922) | 36.8(934) | 53.5(1358) | 15.6(395) | 3.5 | 5 | 3800(1720) | | |
| | N450 | 177.2(4500) | 79.9(2030) | 218.7(5556) | 202.0(5132) | 38.7(984) | 55.4(1408) | 15.6(395) | 3.5 | 5 | 3600(1630) | | |
| Triplex mast | N470 | 185.1(4700) | 83.7(2125) | 222.6(5656) | 208.5(5295) | 46.5(1180) | 60.2(1530) | 15.4(390) | 3.5 | 5 | 3357(1523) | | |
| | N480 | 189.1(4800) | 83.9(2130) | 230.6(5856) | 213.5(5422) | 42.7(1084) | 59.4(1508) | 15.6(395) | 3.5 | 5 | 3400(1540) | | |
| | N500 | 196.9(5000) | 86.8(2205) | 238.0(6046) | 221.3(5622) | 45.6(1159) | 62.3(1583) | 15.6(395) | 3.5 | 5 | 3200(1450) | | |
| | N550 | 216.5(5500) | 93.7(2380) | 257.7(6546) | 241.0(6122) | 52.5(1334) | 69.2(1758) | 15.6(395) | 3.5 | 5 | 3000(1360) | | |
| | N600 | 236.2(6000) | 101.6(2580) | 277.4(7046) | 260.7(6622) | 60.4(1534) | 77.1(1958) | 15.6(395) | 3.5 | 5 | 2600(1180) | | |
| | N650 | 255.9(6500) | 111.4(2830) | 297.1(7546) | 280.4(7122) | 70.2(1784) | 86.9(2208) | 15.6(395) | 3.5 | 5 | 2200(1000) | | |

With sideshifter minus 400lb(200kg),with integral sideshifter minus 200lb(100kg).

Battery and compartment size

| Model | CPDS15 | CPDS16/18 | CPDS20 | CPDS15 | CPDS16/18 | CPDS20 |
|---------------------|----------|--------------|---------------|---------------|--------------|---------------|
| Voltage | 48 | 48 | 48 | 36 | 36 | 36 |
| Capacity | 400 | 500 | 600 | 575 | 690 | 805 |
| Battery Compartment | "X" Max. | 830(32.68) | 830(32.68) | 830(32.68) | 830(32.68) | 830(32.68) |
| | "Y" Max. | 522(20.55) | 630(24.8) | 738(29.06) | 522(20.55) | 738(29.06) |
| | "Z" Max. | 627(24.69) | 627(24.69) | 627(24.69) | 627(24.69) | 627(24.69) |
| Batt.Wt. | Maximum | 740(1631.42) | 1000(2204.62) | 1100(2425.08) | 740(1631.42) | 1100(2425.08) |
| | Minimum | 610(1344.82) | 850(1873.93) | 900(1984.16) | 610(1344.82) | 850(1873.93) |

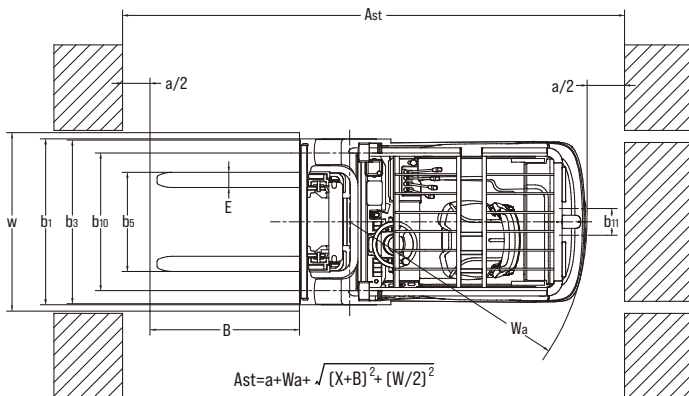
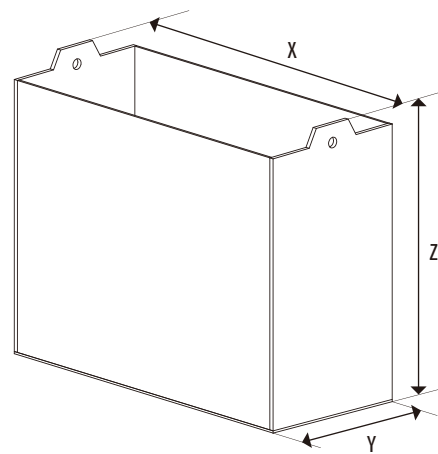
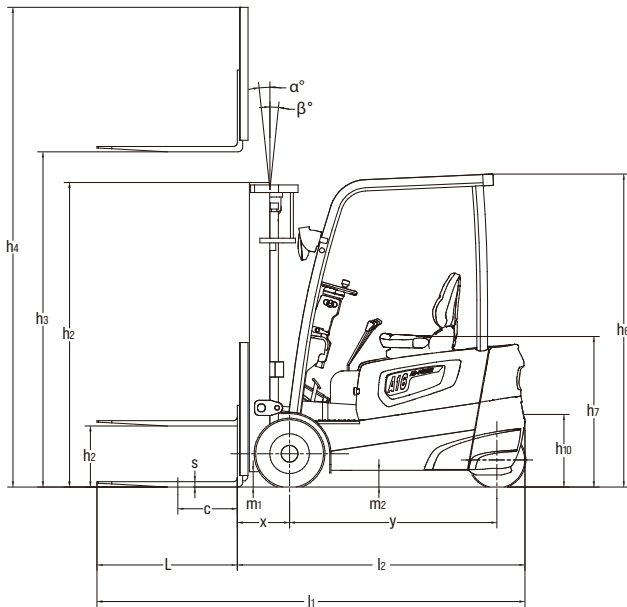

$$Ast = a + Wa + \sqrt{(X+B)^2 + (W/2)^2}$$

X: Load distance
B: Length of load or forks which is longer

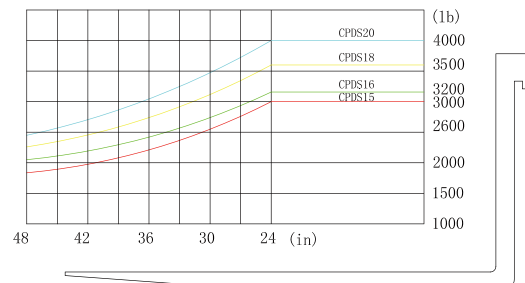



HANGCHA FORKLIFT CANADA INC.

Company address:

6-980 Rue Valois, Vaudreuil-Dorion,
QC, J7V 8P2, Canada

Toll Free: 877-319-HCFC (4232)
Landline: 450-319-HCFC

info@hcforkliftcanada.com
www.hcforkliftcanada.com



Follow us on
Facebook



Follow us on
YouTube



Follow us on
WeChat



Download "Hangcha
Forklift" App

HANGCHA GROUP CO., LTD. reserves the right to make any changes without notice concerning colors, equipment, or specifications detailed in this brochure, or to discontinue individual models. The colors of trucks, delivered may differ slightly from those in brochures.