

BGNR-30

A flexible solution for tight spaces, high pallet stacks, and other application challenges. Reach with ease. Steer with power.

CAPACITY

- 3000 lb (1361 kg) at 24" (610 mm) load center

BATTERY

- Minimum battery* weight: 550 lb (249 kg)
- Compartment dimensions (open): 31.6" x 9.06" (803 x 230 mm)
- Connector: Anderson 175 Gray—A-11

SPEED

- **EMPTY:** 0 - 3.4 mph (5.5 kph)
- **LOADED:** 0 - 3.1 mph (5 kph)

- **LIFT - EMPTY:** up to 40 fpm
- **LIFT - LOADED:** up to 35 fpm with 3000 lb (1361 kg) load

- **LOWERING - EMPTY:** up to 29 fpm
- **LOWERING - LOADED:** up to 57 fpm with 3000 lb (1361 kg) load

TIRES / WHEELS

- **DRIVE:** 10" x 4" (254 x 102 mm) polyurethane
- **DUAL LOAD:** (2) 4" x 2.75" (102 x 70 mm) polyurethane

HYDRAULICS

- Lift cylinder has hard chrome-plated rods
- Pump unit including motor, solenoid, gear pump, and pressure compensated lowering valves

ELECTRICAL

- 24-volt ZAPI AC-0 inverter, travel control and matching drive motor provides high performance throughout the entire speed range
- Separately fused power control circuits
- Quick disconnect EPD power cut off
- Hour meter / battery discharge indicator combo
- Power configurations and diagnostic features are displayed with a ZAPI handheld console
- Low battery interrupt
- Travel speed remains constant relative to throttle position, regardless of load

BRAKES

- Regenerative electromagnetic brake mounted on motor armature shaft, multiplying braking power through the transmission
- Brake is applied when control arm is in the vertical or horizontal position
- Neutral braking resists rollback on ramps

OPERATION / CONTROLS

- Ergonomic operator handle with travel, lift, and lower functions
- Angle grips allow easy operation with either hand
- Wrap-around guard
- Reversing switch



- Thumb control
- Key switch and horn
- Top mounted tiller arm offers excellent operator comfort and minimum steering effort
- Gas-assisted spring handle
- Creep speed handle control

TRANSMISSION

- Vertically mounted drive motor direct mounted to gear housing
- Oil-bathed ZF GK10 hypoid bevel gear drivetrain
- State-of-the-art optimized gear technology provides minimal envelope circle, zero maintenance, and low noise level

FRAME AND MAST

- Bolt-on high-visibility mast, I-beam construction and lift cylinders positioned on outer I-beam for best view through mast
- Dual lifting chains
- Fixed straddle leg inside dimension (ID) of either 34" or 42" (864 mm or 1067 mm)
- 4" (102 mm) wide straddle legs = ID + 8" (203 mm)
- Class II ITA fork carriage with 36" (914 mm) tall load back rest
- Forks are adjustable from 8" ID to 31" OD (203 mm to 787 mm)

BEARINGS

- **DRIVE WHEEL:** tapered roller bearings sealed in oil bath
- **LOAD WHEELS:** sealed ball bearings

ACCESSIBILITY

- Removal of two piece power head cover exposes major components for inspection and maintenance

STANDARD EQUIPMENT

- Power steering
- Pantograph with sideshift and tilt

- ClearView polycarbonate mast guard
- Proportional lift, lower and extend
- Regenerative neutral braking
- Low battery interrupt
- Hour meter BDI combo gauge
- Key switch

OPTIONAL EQUIPMENT

- 10" (254 mm) single load wheel
- Straddle ID/OD of 34/42 or 42/50
- 224 AH AGM battery pack with 110V charger
- Industrial battery 255 AH with external charger

Right Angle Stacking Aisle Dimensions

Load Length	Load Width		
	36"	40"	48"
36"	79.5"	79.5"	79.5"
40"	81"	81"	81"
48"	85.3"	85.3"	85.3"

For ease of use add 8" to aisle dimension listed. If sideshift option is used add 2".

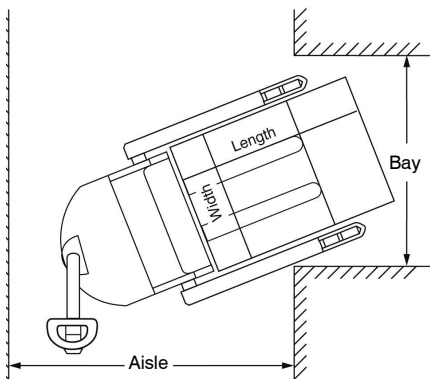

Note: Aisle dimensions listed above assume the minimum bay width to be straddle OD plus 5" (2.5" on each either side of straddle leg). Straddle OD is the load width plus 10". Truck performance may vary due to application requirements and changes in model design.

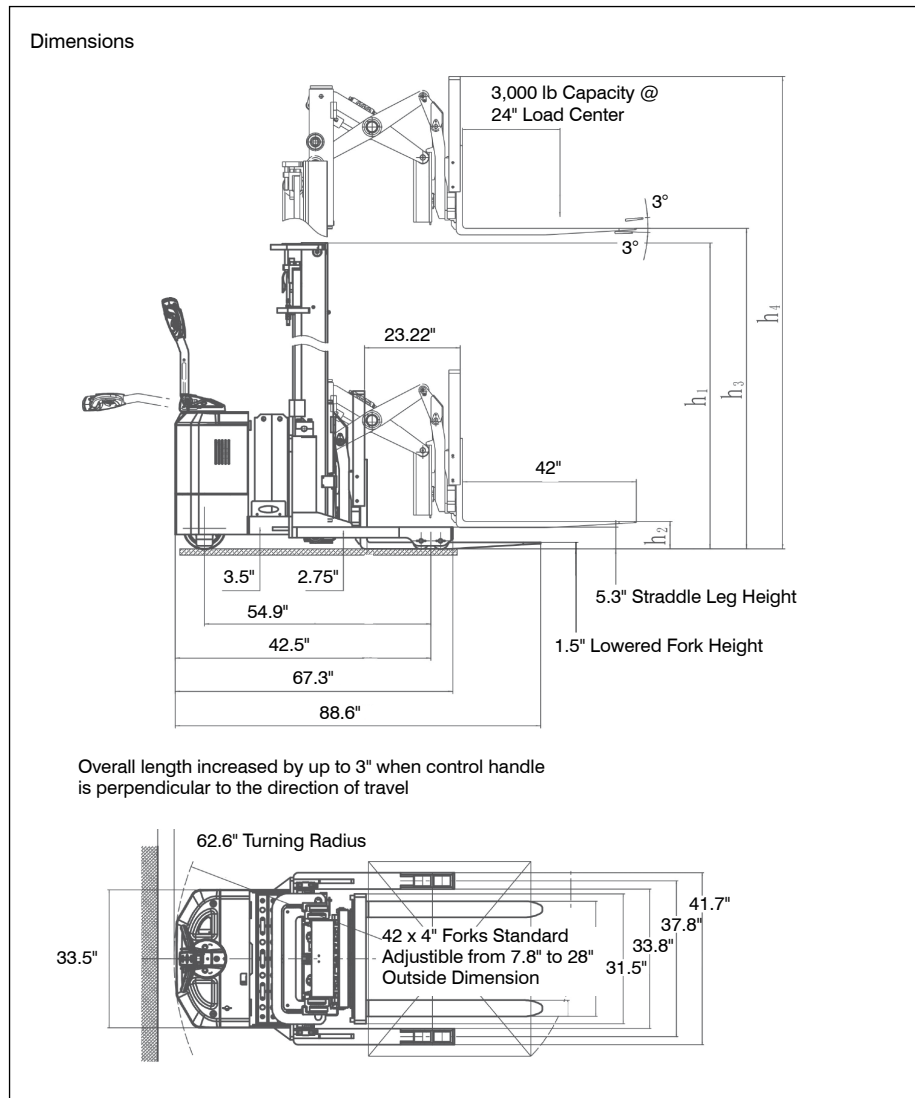

Model#	Mast	Lift Height	Col Height	Free Lift	Ext Height w/ LBR	² Fixed Straddle Leg (4" Increments)		³ Weight (Chassis Only)
		A	C	D	E	ID	OD	
				F	G			
3000 lb Capacity @ 24" Load Center ITA Class II Fork Carriage								
BGNR-30-106	Two Stage	106"	76.5"	6.5"	144.25"	42 or 50"	50" or 58"	3690 lb
BGNR-30-126		126"	83"	6.5"	166.75"			3750 lb
BGNR-30-157	Three Stage	157"	77.25"	39.25"	195.25"			3980 lb

² Derates 1000 lb above 162"
³ Minimum inside dimension (ID) 38". Outside dimension = inside dimension + 8"
³ Estimated shipping weight without battery



Corporate 85 Heart Lake Road South
 Brampton, ON, Canada L6W 3K2
 t 905.457.3900 f 905.457.2313

USA 6350 Burnt Poplar Road
 Greensboro, NC 27409
www.BlueGiant.com



Blue Giant offers a full line of dock levelers, dock safety equipment, seals and shelters, accessories, ergonomic and scissor lift equipment and industrial trucks. Concurrent with our continuing product improvement program, specifications are subject to change without notice. Please contact Blue Giant for latest information. Some features illustrated may be optional in certain market areas.