

OPERATOR'S MANUAL

EPT HAND PALLET TRUCK



WARNING

Do not operate or service this product unless you have read and fully understand the entire contents of this manual. Failure to do so may result in property damage, bodily injury or death.

BLUE GIANT[®]

ISSUE DATE: APRIL 3, 2014 REV.0 (PART # 038-XXXEO)

SAFETY PROCEDURES

SAFETY PROCEDURES

- 1. Do not operate this truck unless you have been trained and authorized to do so.*
- 2. Do not operate this truck until you have read and understood all of the safety information and instructions contained herein and on the truck.*
- 3. Do not operate this truck until you have checked its condition. Give special attention to wheels, controls and lifting systems, including steering mechanism, guards and safety devices.*
- 4. Report the need for truck repairs to your supervisor immediately and do not operate truck until repairs are made. Neglect may cause a minor repair to become a major service problem and cause the truck to become unsafe.*
- 5. Do not load truck beyond capacity shown on serial name plate on truck.*
- 6. Do not lift with the fork tips or one fork only.*
- 7. This equipment is designed for evenly centered loads with forks completely supporting the load. Off-centering of loads can result in a dangerous operating condition and may cause damage or injury.*
- 8. Always look in direction of travel. Use caution when visibility is obstructed by load.*
- 9. Extreme caution must be used when handling loosely stacked/package loads.*
- 10. Watch swing clearance when turning near walls, racks, pillars or other obstacles.*
- 11. Start, stop, change direction and travel smoothly. Slow down for turns and on uneven or slippery surfaces that cause truck to slide or tip. Be aware that the truck behaves differently without a load than with a load.*
- 12. Observe applicable traffic regulations. Yield right of way to pedestrians.*
- 13. Do not ride on this equipment.*
- 14. Do not carry passengers or lift personnel.*
- 15. Before you leave the truck, fully lower lifting mechanism.*

EXCLUSION OF LIABILITY

The manufacturer assumes no liability for damage or injury to persons or property which has occurred as a result of defects or faults in the hand pallet trucks delivered or due to incorrect use. The manufacturer also assumes no liability for lost profits, operating down times, or similar indirect losses which the buyer has incurred. Damage to third parties, irrespective of its nature, is not subject to compensation

The operating instructions are not subject to notification of amendment. The descriptions and illustrations included in our operating instructions and replacement parts list are not binding. In the interests of further development, we reserve the right to make any changes at any time to the modules, components and accessories which we deem to be expedient, or for technical reasons, while retaining the essential features of the models described here.

TABLE OF CONTENTS

Safety	1
Table of Contents	2
Owner's Record of Purchase	2
Warranty	2
Check Shipment Notice	3
Loading Specification	3
Maximum Inclines Or Decline Grades	3
Safety With Tall Loads	3
Unit Specification	4
Assembly	5
Before Use	5
Operation Instructions	6
Service Checklist	7
Trouble Shooting	8
Parts Breakdown	
Handle & Pump Assembly Drawing	9
Handle & Pump Assembly Parts List	10-11
Frame Assembly Drawing	12
Frame Assembly Parts List	13-14

WARRANTY

The guarantee includes material and assembly defects on parts which prove to be incorrect or inadequate for normal use when tested by the manufacturer and which are returned to the manufacturer free of charge within the guaranteed period of 24 months.

The guarantee expires if inappropriate or unadvised repair is undertaken by the user.

Blue Giant offers a full line of dock levelers, dock safety equipment, accessories, ergonomic and scissor lift equipment, and industrial trucks. Concurrent with our continuing product improvement program, specifications are subject to change without notice. Please contact Blue Giant for latest information. Some features illustrated may be optional in certain market areas.

OWNER'S PURCHASE RECORD

Dealer:	Date in Service:
Owner:	Number of Units:
Order Number:	Year of Construction:
Serial Number(s):	

CHECK SHIPMENT BEFORE ASSEMBLY AND/OR USE

The hand pallet truck is to be carefully checked at the manufacturer's plant before shipment. In order to ensure that no damage has occurred during transport, the hand pallet truck should be checked upon receipt for transport damage and to ensure correct operation. Damage due to transport is to be listed on the signed copy on the freight document. The freight forwarder must be notified of any damage within 48 hours. Damaged hand pallet trucks must not be put into use.

LOADING SPECIFICATION

The hand pallet truck is designed for the horizontal transportation of loads on a level, fixed base. The load must be evenly distributed on pallets or similar receptacles. The ideal loading mode is that the gravity center of heavy goods is at the central position of the fork. The maximum load-carrying capacity is shown on the appropriate designation plate and on the load sticker on the hand pallet truck. When there exists defective load, the rated carrying capacity shall be reduced. If the load on the forks is one sided, there is a risk of the forks bending or the load slipping off. Supporting or shifting the load with the fork tips is to be avoided in all cases as this results in damage to the appliance. In order to preserve the wheels and chassis the hand pallet truck must not be driven over very uneven ground.

MAXIMUM INCLINES OR DECLINE GRADES

The hand pallet truck is equipped with a permanently set pressure-limiting valve which permits a maximum load of 5 % of the nominal load. The screw plug on the pressure control valve is secured so as to avoid inappropriate manipulation from the operating personnel. In order to avoid damage to the goods being transported and the means of transport, the load must be supported evenly. If the load is unevenly distributed the pressure limiting valve will not function. When driving on down-grades the load is to be secured to prevent it from slipping or sliding off the hand pallet truck, (e.g. additional operating personnel). In addition to this, only hand pallet trucks with a service and parking brake are to be used on down-grades up to approx 6 %.

Journeys on inclines or down-grades of more than 6 % are always to be avoided. Safe transport cannot be guaranteed when the center of gravity of the load has altered.

SAFETY WITH TALL LOADS

Transporting with tall loads, (e.g. machines) changes the center of gravity of the load so unfavorably that the complete hand pallet truck including the load, goes out of control and may overturn on a curve. Loading, (e.g. onto a truck or mobile loading ramps) should be regarded in particular as likely occasions for accidents. During such activities the hand pallet truck is to be secured with particular care.

Conveying persons or using the hand pallet truck as a form of roller skate is not permissible. Foodstuffs are only to be transported in packed form. Direct contact with the hand pallet truck is to be avoided.

The accident prevention regulations for industrial trucks and the safety regulations and accident prevention regulations applicable to the user are also to be complied with.

EPT-55 SPECIFICATIONS

The following data must always be specified to ensure correct processing of your spare parts order:

- a) Truck type (capacity)
- b) Serial number of the truck
- c) Complete Part Number

ASSEMBLY DRAWINGS:

Handle & Pump Assembly
Frame Assembly

Weight:

160 lbs (72.575 kg)

Capacity:

EPT-55

5,500 lbs (2,300 kg)

Fork length: 48" (1,220 mm)

Please fill in Owner's Purchase Record the following details:

- serial number(s)
- dealer name
- date in-service
- owner's name
- order number
- year of construction

ASSEMBLY INSTRUCTIONS:

Individual trucks are assembled and ready to use. Pallet trucks purchased in crate quantities (6 units to a crate) require some assembly. Tools Needed for Assembly • 5 mm / 8 mm Allen Key

3.1 Remove screw (No. 1), before pulling axle pin (No. 2).

3.2 Insert handle (No. 3) at position (No. A) and connect handle (No. 3) to pump body (No. 4) insert axle pin (No. 2) then use Allen Key to fasten screw (No. 1) to attach axle pin (No. 2).

3.3 Put screw and nut at the end of roller chain (No. 5) into the slot of lever pad (No. 6).

3.4 Pull the handle to horizontal position, pull out pin (No. 7) and keep it stored for future handle replacement.

3.5 The assembly is completed.

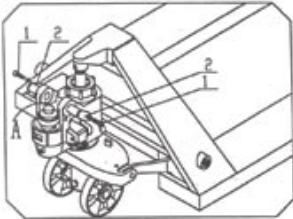

1.

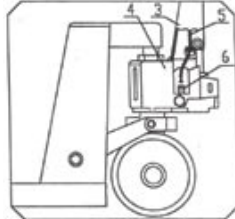

2.

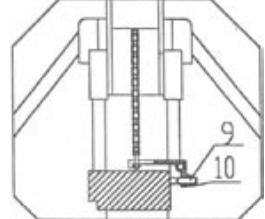

3.



Before Use

4.1 After finishing the assembly of the pallet truck, try to shake it and operate the unit in different positions using the hand lever, to see whether the lifting, neutral position and lowering the pallet truck operates properly.

4.2 The outer hexagonal nut (No. 10) at bolt location (No. 9) is used for locking, and must be loosened before any adjustment and must be tightened after adjustment. If the pallet truck is raised and the pallet truck immediately descends, turn screw bolt (No. 9) anti-clockwise a little at a time and test the pallet truck until normal lifting has occurred. If the pallet truck cannot be lowered after lifting, turn screw bolt (No. 9) clockwise a little at a time and test the pallet truck until normal lowering has occurred. After adjustments lock outer hexagonal nut (No. 10) at bolt location (No. 9) back into place.

OPERATING INSTRUCTIONS

NOTES ON USE

There is a hand lever on the drawbar for raising and lowering the hand pallet truck. This can be moved into three positions:

- | | |
|----------------|--|
| Lift | - lever down |
| Drive position | - lever in neutral position when moving load (center position) |
| Lower | - lever up, truck will lower at selected rate of speed |



To pull the hand pallet truck, always move the hand lever into the drive position. This makes the drawbar easier to move and depressurizes the pump section of the hydraulics. This preserves the hydraulic seals and the valve components. A longer service life can be expected.

The hand pallet truck is largely maintenance-free. Only the oil level has to be checked and topped up if necessary. All bearings and shafts are provided with long-life grease at the factory.

All lubrication points marked (→) in the "chassis" replacement parts list are to be provided with long-life grease at monthly intervals or after each time the truck is cleaned thoroughly.

NOTE

When the hand pallet truck is used under extreme conditions (e.g. extreme heat or cold, very dusty conditions etc.), the stipulated intervals are to be appropriately reduced.

SERVICE CHECK LIST

OPERATION	<p>A. With control lever in lift position, pump the handle a few strokes to lift load.</p> <p>B. Move control lever to neutral position to free handle of all pumping force.</p> <p>C. To lower load, pull the lever until the load starts lowering or the selected lowering speed has been reached.</p>
CHECKING OIL LEVEL	With the truck in the lowered position on a level surface, remove filter screw, oil should be level with filler screw hole, if not add the proper oil. Check filler screw seal before replacing.
RECOMMENDED HYDRAULIC OIL	The hydraulic oil required for the hydraulic pump is roughly 0.5 pints (250 ml). The ISO oil quality standard is used. When the ambient temperature is -5° to 40°C, #32 oil is used; and when the ambient temperature is -35° to -5°C, the low temperature hydraulic oil is to be used.
Maintenance	Conduct routine inspection everyday to eliminate future problems from occurring. Do not use pallet trucks that are not working properly. Add motor oil to each rotating joint once every three months.

TROUBLE SHOOTING GUIDE

CONDITION	CAUSE	ACTION
Insufficient lifting	A. Shortage of oil B. Air in pump	A. Add appropriate filtered working oil B. Set operation lever to lowering position and pump handle repeatedly
Pallet truck does not completely lower	A. Too much hydraulic oil has been added B. Rotating part is distorted and gets stuck	A. Pump off appropriate amount of hydraulic oil B. Replace parts
Pallet truck does not lower after lifting	A. The lowering device is abnormal B. Components are distorted and damaged	A. Re-adjust the lowering device. See Before Use 4.2 B. Replace required parts
Hydraulic oil leaks	A. The seal is damaged B. There is a slight breakage or abrasion on the surface of individual parts. C. Loose joint	A. Replace the seal B. Replace the damaged parts C. Tighten loose joint
Pallet truck does not lift	A. Viscosity of hydraulic oil is too high or hydraulic oil level is too low B. Hydraulic oil is dirty C. The lowering device is abnormal	A. Replace the hydraulic oil B. Replace the hydraulic oil C. Re-adjust the lowering device. See Before Use 4.2
Pallet truck lifts and then immediately descends when handle is pumped The handle has large resistance or the pallet truck automatically descends obviously after lifting	The valve is stuck	Open the valve, take it out then clean the valve and parts. Reinstall valve and parts to their original position

HANDLE & PUMP ASSEMBLY DRAWING

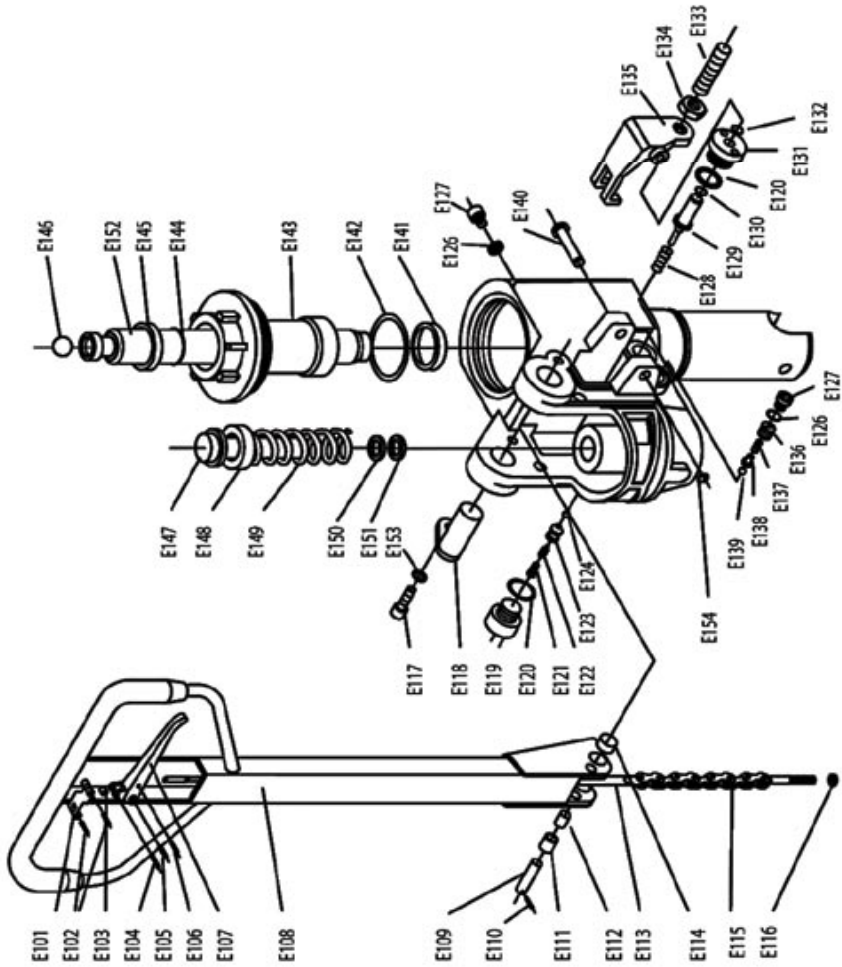

HANDLE & PUMP ASSEMBLY PARTS LIST

Drawing Reference Number	Blue Giant Part Number	Quantity Per Unit	Description
B101	080-7E102	1	Control Handle Spring Pin
B102	080-7E103	2	Control Handle Roller
B103	080-7E104	1	Control Handle Locking Pin
B104	080-7E105	1	Control Handle Locking Pin
B105	080-7E106	1	Control Handle Locking Pin
B106	080-7E107	1	Control Handle Lever
B107	080-7E108	1	Handle Shell
B108	080-7E109	1	Handle Pin
B109	080-7E110	1	Locking Pin
B110	080-7E111	1	Handle Pressure Roller
B111	080-7E112	1	Handle Pin Bushing
B112	080-7E113	2	Control Handle Rod
B113	080-7E114	1	Handle Bushing
B114	080-7E115	2	Chain
B115	080-7E116	1	Nut
B116	080-7E117	1	Screw
B117	080-7E118	2	Handle Pivot Pin
B118	080-7E119	2	Screw Plug
B119	080-7E120	1	Copper Washer
B120	080-7E121	2	Spring
B121	080-7E122	1	Damping Valve Spindle
B122	080-7E123	1	Damping Valve Seat
B123	080-7E124	1	Ball Valve
B124	080-7E126	1	Copper Washer
B126	080-7E127	2	Bolt
B127	080-7E128	2	Spring
B128	080-7E129	1	Strike Pin
B129	080-7E130	1	O-Ring
B130	080-7E131	1	Sleeve

HANDLE & PUMP ASSEMBLY PARTS LIST

Drawing Reference Number	Blue Giant Part Number	Quantity Per Unit	Description
B131	080-7E132	1	O-Ring
B132	080-7E133	1	Adjusting Screw
B133	080-7E134	1	Nut
B134	080-7E135	1	Lever Plate
B135	080-7E136	1	Bolt
B136	080-7E137	1	Spring
B137	080-7E138	1	Ball Valve Seat
B138	080-7E139	1	Ball Valve
B139	080-7E140	1	Lever Plate Bolt
B140	080-7E141	1	U-Cup
B141	080-7E142	1	O-Ring
B142	080-7E143	1	Cylinder Cap
B143	080-7E144	1	O-Ring
B144	080-7E145	1	Wiper
B145	080-7E146	1	Steel Ball
B146	080-7E147	1	Pump Piston
B147	080-7E148	1	Washer
B148	080-7E149	1	Handle Return Spring
B149	080-7E150	1	Wiper
B150	080-7E151	1	U-Cup
B151	080-7E152	1	Lift Piston
B152	080-7E153	1	Washer
B153	080-7E154	1	Retaining Ring
B154	080-7E155	1	Seal Packing Kit

FRAME ASSEMBLY DRAWING

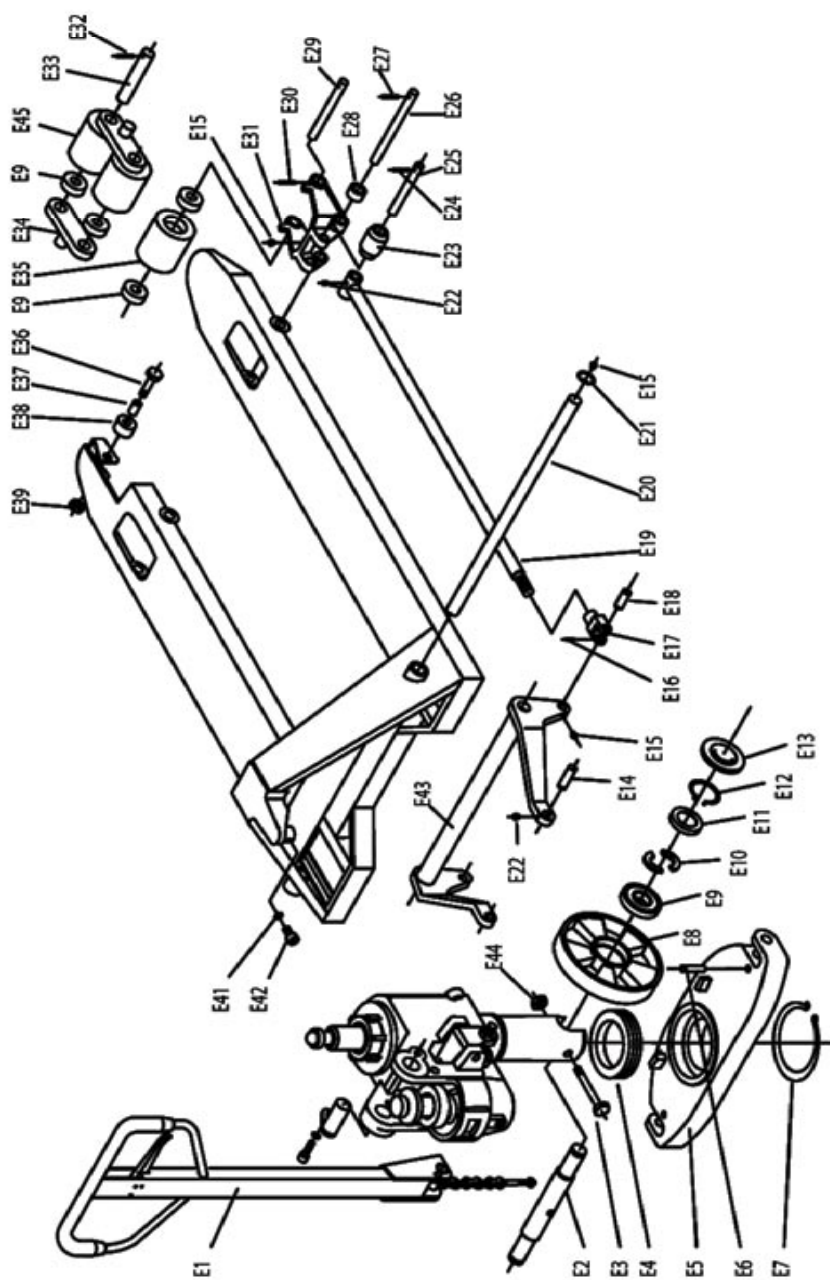

FRAME ASSEMBLY PARTS LIST

Drawing Reference Number	Blue Giant Part Number	Quantity Per Unit	Description
-----	080-7E0	1	Complete Pump Assembly
B1	080-7E1	1	Handle Assembly
B2	080-7E2	1	Steer Wheel Axle
B3	080-7E3	1	Steer Axle Bolt
B4	080-7E4	1	Thrust Bearing
B5	080-7E5	1	Thrust Plate
B6	080-7E6	2	Thrust Plate Pin
B7	080-7E7	1	Locking Ring
B8	080-7E8	2	Steer Wheel Polyurethane
-----	080-7E8N	2	Steer Wheel - Nylon
-----	080-7E8NW	2	Steer Wheel- Nylon (white)
-----	080-7E8S	2	Steer Wheel - Steel
B9	080-7E9	8	Bearing
B10	080-7E10	4	Half Round Locking Ring
B11	080-7E11	2	Lock Ring Cover
B12	080-7E12	2	Locking Ring
B13	080-7E13	2	Hub Cap
B14	080-7E14	2	Bell Crank Pin
B15	080-7E15	8	Oiler
B16	080-7E16	2	Joint Locking Pin
B17	080-7E17	2	Joint
B18	080-7E18	2	Joint Pin
B19	080-7E19	2	Push Rod
B20	080-7E20	1	Bell Crank Shaft
B21	080-7E21	2	Locking Ring
B22	080-7E22	4	Oiler
B23	080-7E23	2	Guide Sheath
B24	080-7E24	2	Push Rod Locking Pin
B25	080-7E25	2	Push Rod Pin
B26	080-7E26	2	Hanger Axle

FRAME ASSEMBLY PARTS LIST

Drawing Reference Number	Blue Giant Part Number	Quantity Per Unit	Description
B27	080-7E27	2	Hanger Axle Locking Pin
B28	080-7E28	4	Rear Guide Roller
B29	080-7E29	2	Roller Axle
B30	080-7E30	2	Hanger Axle Locking Pin
B31	080-7E31	2	Hanger
B32	080-7E32	8	Tandem Roller Axle Locking Pin
B33	080-7E33	4	Tandem Roller Axle
B34	080-7E34	4	Tandem Roller Bogie Link
B35	080-7E35	2	Load Roller - Polyurethane
-----	080-7E35N	2	Load Roller - Nylon
-----	080-7E35S	2	Load Roller - Steel
B36	080-7E36	2	Front Guide Roller Bolt
B37	080-7E37	2	Bushing
B38	080-7E38	2	Front Guide Roller
B39	080-7E39	2	Nut
B41	080-7E41	1	Bulkhead Washer
B42	080-7E42	1	Bulkhead Bolt
B43	080-7E43	1	Bell Crank
B44	080-7E44	1	Steer Axle Nut
B45	080-7E45	4	Tandem Load Roller - Polyurethane
-----	080-7E45S	4	Tandem Load Roller - Steel
-----	080-7E46Y	1	Touch up paint, can (yellow)
-----	080-7E101	4	Control Handle Spring

NOTES:

NOTES:

BLUE GIANT[®]
BLUE GIANT EQUIPMENT CORPORATION

Corporate 85 Heart Lake Road South
Brampton, ON, Canada L6W 3K2
t 905.457.3900 f 905.457.2313

USA 6350 Burnt Poplar Road
Greensboro, NC 27409
www.BlueGiant.com