



Linde Material Handling

Linde

VNA

Optimize your performance

Linde solutions for VNA applications



What is VNA?

Do you need to increase the flow of goods in your warehouse? Store more pallets within the same space? Bring a storage area on site? Free up some storage space for more production?

The ever-growing need to make more efficient use of space has led many companies to turn to Very Narrow Aisle (VNA) solutions.

VNA can help you handle more goods in less time, and in less space. VNA installations can cope with both full pallet handling – storage and retrieval – and order picking. And provide an effective way of organizing the internal flow of goods to achieve high throughputs.

VNA – ideal for both new and existing warehouses.

VNA installations meet the needs of two types of customer: warehousing and industrial. In one application they enable operators to increase the speed of storage and retrieval and allow use of higher rack levels to increase storage density. In the other, they can free up space for more production or meet the need for more on-site storage.

Space. Whereas conventional warehouse trucks require aisle widths of over 2.7 m, the aisles in a VNA warehouse are around 1.7 m. This alone represents a space gain of some 25%. But VNA racking can also be substantially higher, enabling operators to work at up to 16 m, thereby achieving the highest and most efficient density of goods possible. With standard pallet loads you can expect to store up to 50% more in a Very Narrow Aisle warehouse. Even if an existing warehouse doesn't have the space to install higher racking, the use of space can be optimised by reducing the width of the aisles.

Performance. VNA warehouses enable extremely efficient organization of workflow, high throughput and optimum pallet density. In new-build, purpose-designed VNA warehouses, the performance and throughput will optimize the investment from the outset. In existing warehouses, the space-saving, the productivity increase and the lower running costs will quickly offset the initial investment. Being capable of simultaneous traction and lift gives a VNA truck a substantial advantage over other truck types. This diagonal movement allows the operator to retrieve a pallet from a height of 10 m in the same time as he would a pallet at ground level with another type of truck.

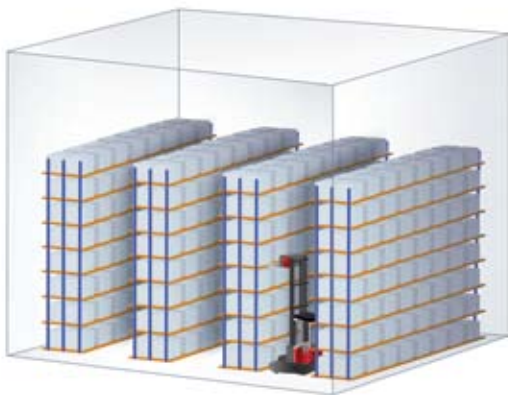

In a conventional warehouse, the aisle width required is over 2.7 m.

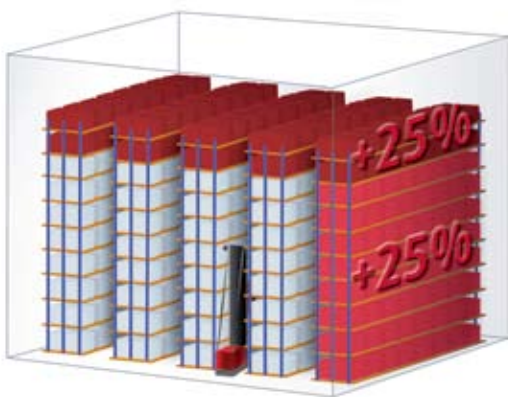

Unlike a conventional warehouse, the aisles in a VNA warehouse are around 1.7 m wide gaining +25% of storage. VNA racking can also be substantially higher, enabling around 50% more storage compared to a conventional racking system.



Linde expertise in tailor-made solutions.

Linde's expertise in designing trucks for VNA warehouses and its modular approach make us your company's ideal partner.

With its three ranges, Linde has a solution for all situations. And using its exclusive VNAP software, Linde trucks **can be customized to meet your need for optimum performance**. Our man-down 'A' range is designed for the storage and retrieval of pallets at lower heights. Our man-up combi 'K' trucks are best-suited for storage and retrieval in high bay warehouses with greater throughput needs, but are also ideal for order picking, whilst the rising cab 'V' range are designed for dedicated order picking at ground level and above.

Linde's specialist VNA sales staff will work with you to identify the optimum configuration to meet your operational and storage needs and select the most appropriate cabin option, performance package, mast, battery and chassis size. Our staff can produce the drawings for you in your office resulting in the perfect tailor-made solution.

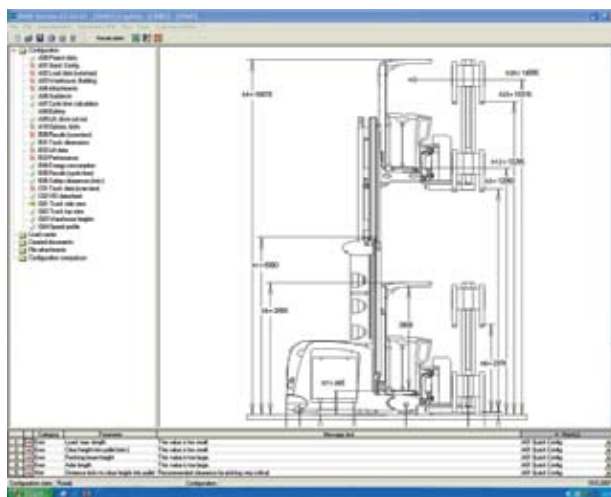
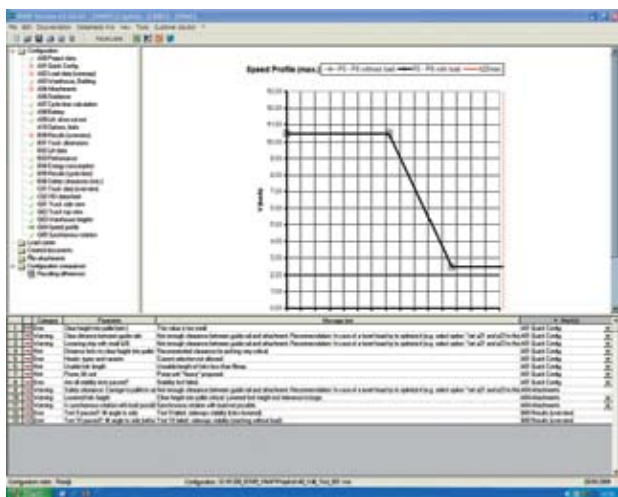



Linde's cutting-edge VNAP software custom-designs **the truck you need.**

Because every customer's needs are different, Linde has developed an exclusive software program called VNAP (Very Narrow Aisle Program) which takes on board the key parameters of your particular application to be entered and then produces the optimum specification to match them. The VNAP software analyzes your site, its constraints and the application requirements. Then you select – on screen – the exact details of your future truck.

Whether your application involves high or medium throughput, medium or high lift heights, light or heavy loads, order picking or full pallet handling – or a combination of these, Linde's Modular Concept can meet all your needs.

Trucks available for VNA applications.

The Linde man-down 'A' range. .

Linde's 'A' range of modular man-down trucks is designed for fast, reliable storage and retrieval of full pallets. This entry model for smaller VNA applications can work at heights of up to 8.5 m.



The Linde Vertical order picking 'V' range.

No matter what beam level goods need to be picked from, whether they are heavy or light, one of Linde's three different VNA order picking trucks will do the job. The manoeuvrable V10 is the truck for light-duty applications picking at heights of up to 6 m. Meanwhile, the more powerful 48 Volt V11 and V12 can work at heights of 7 m and 11 m respectively and are designed for heavier loads.

The V range matches the truck to the operator and his tasks, and combines technical performance with a user-friendly design to making order picking as easy as possible.

Of course, any model in the range can be used just as effectively in free-ranging applications.

V trucks presentation in the brochure "Man-up".



The Linde man up-combi 'K' range.

The Linde 'K' range man-up trucks are the perfect solution for all VNA warehouse applications. These modular combi trucks are designed for high-level full pallet storage and retrieval as well as case picking applications up to 16 m.



High precision for speed and performance. **Linde System Control (LSC).**

Linde has developed innovative technology to ensure perfect control of the performance of its VNA man-up and man-down trilateral trucks. A standard truck is unable to distinguish whether it is carrying a load or not and, thus it needs to be slowed down when lifting in order to retain stability. Linde's VNA trucks, however, are equipped with sensors, which, thanks to Linde System Control (LSC), provide the optimum truck speed. This speed is actually calculated in real time in relation to the weight of the load on the forks. This means the truck only slows down when it is carrying heavier loads. The responsive electronic monitoring system enables the operator to achieve maximum productivity while driving in the aisle and handling loads. Depending on the specific operating conditions, trucks equipped with LSC can deliver up to 30% higher performance than conventional machines.

The major benefits of Linde System Control (LSC) are a dramatic increase in safety, higher load throughput and less damage to trucks and goods. To ensure the highest levels of productivity, Linde trucks are equipped with a height pre-selector system, as well as automatic reach and rotation of the forks, allowing faster and safer load handling.



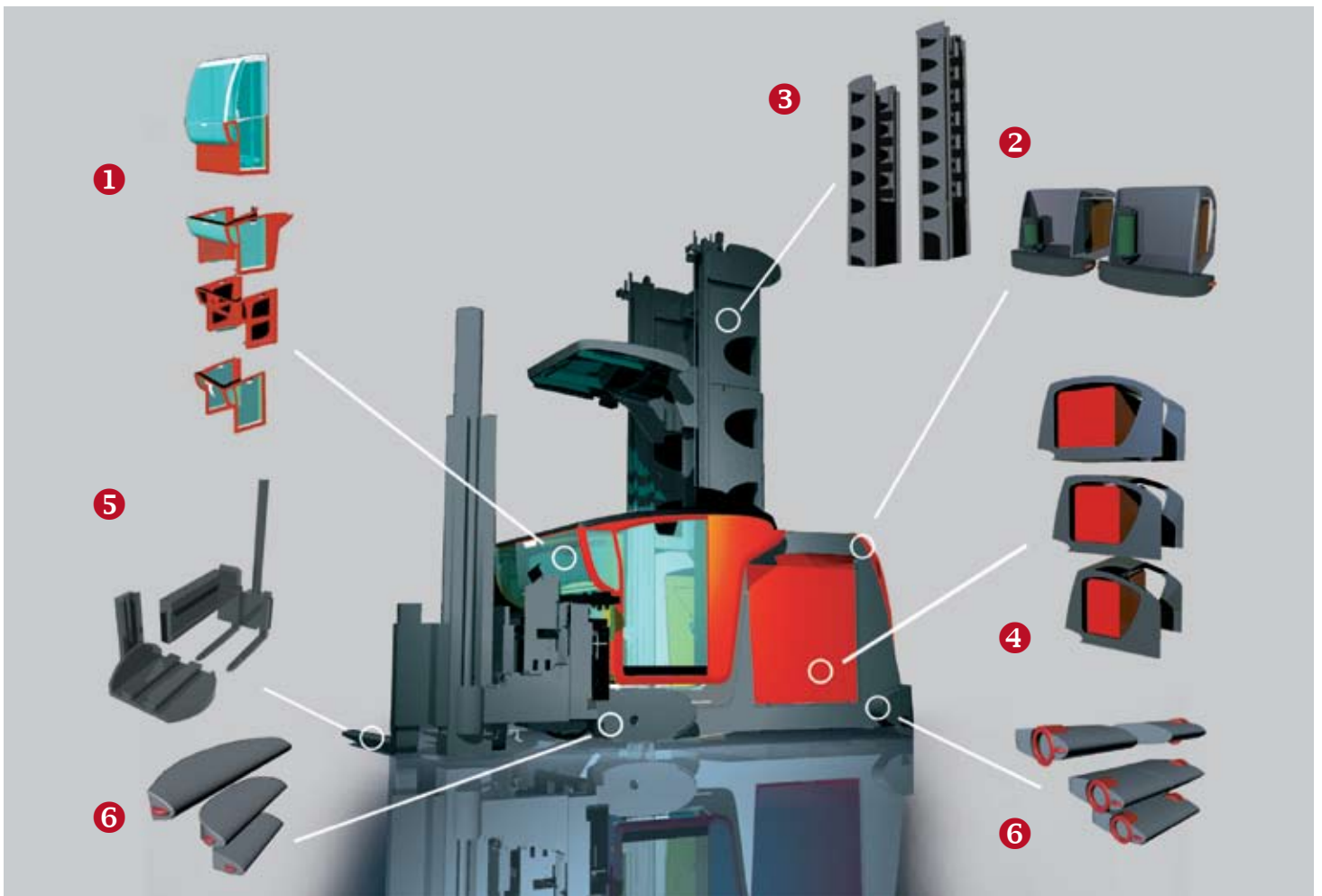

Modularity. Linde's VNA trilateral stacker trucks, the industry's leading technological solution for VNA operations, are custom-designed to meet your specifications. Because every user's requirements are different, the Linde truck isn't just one truck; it's a thousand.

The Linde custom-built man-up combi range to meet your VNA needs.

- 1 Five different cab versions:** Designed to ensure more space and greater freedom of movement. Does your operator need a better view of the forks? Are the goods handled so bulky that you need a wider cab? Or do you work in a chill or cold store? Whatever your requirements the truck can be equipped with a cabin that meets every one of them.
- 2 Power packages:** Depending on the working heights and throughput rates you need, the truck can be equipped with different traction and lift speed combinations.
- 3 Masts:** Are your loads light or heavy? Do you store your pallets at medium height or up to 16 m? We can supply you with the right mast for the task.
- 4 Batteries:** How long are your normal working shifts? How heavy are your loads? What are the throughput ratios? We can equip your truck with the battery capacity you need.
- 5 Load handling and truck guidance:** Do your handling operations mainly involve full pallet loads or case picks? Is better use of available storage space an objective? The Linde Modular Concept provides the solution with either a rotating turret head or telescopic forks and with either rail or wire guidance to match the operational criteria of your existing facilities or a planned new site.
- 6 The optimal chassis size:** Compared with conventional combi trucks, Linde trucks are extremely robust, torsion-resistant and compact due to their reduced chassis length. They set new standards in rapid guide wire acquisition and aisle transfer in order to reduce end-aislewidths.

The Linde man up-combi 'K' range.

Comfort. Linde's man-up trucks provide the highest standard of comfort, safety and reliability. We are an operator-focused manufacturer: operators immediately feel at ease as soon as they drive a Linde K truck. We strongly believe the more comfortable, functional and ergonomic the truck is, the more relaxed and efficient the operator will be. Features such as the glass front panel and doors ensure excellent visibility for the operator and protection against wind and drafts.

Safety. The control console was designed to be safe and intuitive to operate, with a well organized display and touch sensors to ensure two-handed operation. The status of options such as Personal Safety Equipment or wire guidance are displayed on the operator's control console. Along with LSC for speed and stability control, Linde K trucks benefit from two independent braking systems: electric regenerative braking activated when the operator's hand releases the accelerator or changes direction; and a two-stage electromagnetic spring-loaded parking and emergency brake acting on the motor shaft.

Reliability. Linde's K range is exceptionally reliable, and requires very little servicing and maintenance. The optional GPRS service is a non-line diagnostic feature enabling the truck to report a fault directly to a technician via SMS.

Productivity. The modular design ensures a tailor-made solution for each application. The cabin is ergonomically designed to ensure that the operator has excellent visibility of the pallets when seated.

Energy. The energy recovery system ensures a long battery shift life. The lifetime of the battery is extended through intelligent energy control which manages the maximum battery current draw.







The Linde man-down 'A' range for optimum storage efficiency in Very Narrow Aisles.

Modularity. The man-down A range is a modular concept truck so many of its parameters can be selected to meet your requirements. This can be decided in the comfort of your office using our specially developed Linde VNAP tool. You can choose from a variety of different power packages for traction and lift, masts, chassis, batteries and performance options.

Comfort. The A range benefits from Linde's operator-focused design. Ergonomics and comfort are the key words. The operator's compartment is designed to meet his needs, and to enable him to accomplish his tasks. The adjustable seat and pedals have been designed to ensure a fatigue-free operating position so that the operator can focus fully on his tasks. The joystick makes operation easy as all functions can be accessed without changing hands. This ensures both comfort and high performance.

Safety. A range of different functions, such as the optional camera system for driving and stacking, guarantee safety. The optional laserpointer shows the operator the exact position of his forks and helps him to stack or retrieve pallets quickly and safely.

Reliability. Linde's man-down range is built in our German production site using the latest AC technology. The trucks are well protected and encapsulated. The sealed maintenance-free motors are extremely durable. But in the event of a fault the optional GPRS service ensures a quick solution.

Productivity. The sideways-seated driving position helps the operator achieve high pallet throughput. Powerful traction and lift motors guarantee high performance and productivity. Thanks to the Linde System Control (LSC) the optimum performance is calculated in realtime in relation to the load carried – a great advantage for maximum throughput.





With annual sales exceeding 100,000 forklift trucks, Linde ranks among the world's leading manufacturers. This position has been justly earned. Linde trucks excel not only with their recognized innovative technology but especially due to their low energy and operating costs.

High quality in production is matched by the standard of the service we provide. With our ten manufacturing plants and a comprehensive network of local partners, we are at your call around the clock and around the world.

Your local Linde dealer offers a complete single-source package including qualified pre-sales consulting, after-sales service and flexible finance options—whether leasing, renting or purchasing.

Linde Material Handling North America Corporation
2450 West 5th North Street, Summerville, SC 29483
Phone: 843.875.8000 • Truck Sales Fax: 843.875.8471
E-mail: trucksales@lmh-na.com • www.lmh-na.com

