

Operator controls

The top-mounted operator control handle features heavy-duty cast design and construction. Soft-touch accelerator twist grips govern travel direction and speed and feature automatic return to neutral. Integral, easy-to-use push button control switches actuate lift/lower and horn. All the truck's basic controls can be operated by a left or right-handed operator without them having to remove their hands from the roller grips. A reversing switch located at the end of the control handle will automatically reverse travel direction when actuated.

Hand-hold rail (EWR models)

An over-molded driver hand-hold rail, provided on all EWR models, features insulated soft-touch texture to increase driver comfort and productivity. The hand-hold rail is equipped with the same sealed push button switches as the control handle, plus a high-speed selector button.

Riding platform (EWR models)

Ample foot room for left and right-handed drivers is provided by the cushion-mat-covered EWR ride platform. Two massive spring-loaded stability casters, offered as standard equipment, help the operator handle loads quickly and with confidence. The stability casters are yellow zinc-plated with nickel-plated bearing seal protectors for maximum corrosion protection.

Motor compartment covers

The EW/EWR series features glass-filled polyurethane motor compartment covers. These clam shell style covers are a product of the latest scientific advances in the field of polyurethane chemistry. In addition to their resistance to rust and corrosion, these covers offer superior impact strength, durability, lifelong proper fit and are made from 100% recyclable material. The same rugged material is used today by most large construction machinery OEM's.

Brake system

Smooth, controlled braking is accomplished by one of four methods:

1. Control handle in the vertical position
2. Control handle in the horizontal position
3. Regenerative braking (reversing the accelerator twist grips).
4. When the operator control handle is released, a spring automatically returns the handle to the vertical position, which applies the brake and interrupts travel power.

Hydraulic system

A Barnes integral hydraulic pump/motor assembly, featuring a large translucent poly tank that can be sight checked for hydraulic oil level, is mounted vertically to the truck frame. Pump/motor assembly are well-protected and easy to service.

Standard equipment

- Programmable microprocessor-based G.E. Transistor Travel Control (24-V. Trucks)
- G.E. SEM drive motor (24-V. Trucks)
- Regenerative braking (24-V. Trucks)
- Ramp anti-rollback (24-V. Trucks)
- 7/8" nickel-plated linkage pins
- 1" thick heavy-duty linkage tie bars
- Heavy-duty, Teflon-coated, oil-impregnated linkage bushings
- Fail-safe brake and power cutoff
- Horn/key switch
- Reversing switch in control handle
- Lift cutout at maximum fork height
- Bolt-on pallet entry/exit rollers
- High-speed travel lock-in
- High-speed anti-tape-down
- On-board diagnostics
- Sealed harness connectors
- Yellow zinc-plated stability casters

Optional equipment

- Multifunction dash display (24-V. trucks)
- Package guard
- Battery compartment rollers
- Storage tray
- Coast control
- Easy pick system
- Cold storage/corrosion protection
- U.L. EE construction (24-V. trucks only)

Contact dealer/manufacturer for additional equipment availability.



Pallet Trucks

EW60 12/24-Volts 6,000 Lbs.

EW80 24-Volts 8,000 Lbs.



Introduction

This modern truck series offers the following outstanding features:

Design

Maximum operator comfort and productivity define the design parameters of this truck series. All EWR models feature a large fully-cushioned operator platform and soft-touch, over-molded hand-hold rails. All models are equipped with soft-touch operator accelerator control twist grips as well as adjustable control handle return springs.

Frame

Truck frames feature all seam-welded unitized construction. Plate steel contoured to shape for rigid strength provides maximum durability and protection for all vital components. Frame and forks are joined by four heavy-duty structural "L" brackets welded into a rigid unit. The battery compartment is an integral part of the chassis and fork assembly, further adding strength to the frame.

Forks

Trucks are available for both single (1-2) and double (3-4) pallet handling applications. All forks are fully integrated, heavy-duty, one-piece design. Both formed, as well as channel fork designs, are utilized. All forks feature wide skid bars, sloped toes and bolt-on pallet entry/exit rollers for improved performance.

Fork linkage

High strength, solid steel 1" thick rectangular tie bars connect the load wheel shackles to the lifting toggles. The 7/8" diameter linkage pins and Teflon coated/oil-impregnated linkage bushings are designed to withstand severe shock and stress. Full-width load wheels are supported by durable cast steel shackles pivoting on exclusive 7" wide bearing blocks. Zerk grease fittings are standard for fast lubrication and are accessible while the truck(s) is in the upright position.

EWR60 24-Volts 6,000 Lbs.

EWR80 24-Volts 8,000 Lbs.



Drive motor

All 24-volt equipped EW/EWR models feature G.E. (SEM) separately excited drive motors. These high performance motors featuring class-H insulation are open-ventilated for energy-efficient, cool operation. Excellent performance, dependability, control and lowest possible energy consumption are provided through the utilization of quality materials and the matching of motor to drive system. Four long-life motor brushes interface with the diamond-turned commutator.

Drive unit

The EW/EWR series is fitted with heavy-duty, bottom-mounted Kordel drive units. They feature a top seal turntable bearing with encapsulated ball bearings easily lubricated from the top down. These high capacity drive units are precision-machined utilizing heat-treated, chromium alloy steel gears for maximum life and dependability.

Travel control

Microprocessor-based G.E. transistor travel controls are offered as standard equipment on all 24-volt trucks. These ultramodern electronic controls eliminate forward/reverse contactors, numerous relays, resistors and diodes. Standard control features include three unique speed limits, anti-rollback, regenerative braking, high speed lock-in, and high speed anti-tape down. The controls are fully programmable to allow for specific application requirements and feature diagnostic capability with stored fault codes. Sealed wiring harness connectors prevent moisture and contaminants from interrupting truck operation in all environments. In combination with the G.E. SEM drive motor, the electronic package delivers unbeatable truck control and performance with unrivalled energy efficiency.

Manufacturer's Data and Design Characteristics

October 2003



Characteristics		Linde	Linde
1.1	Manufacturer	Linde	Linde
1.2	Model designation	EW60/80	EWR60/80
1.3	Power unit: Electric, Diesel, LP, Other	Electric	Electric
1.4	Operation: Walkie, Rider/Stand, Rider/Sitdown	Walkie	Walkie/Rider
1.5	Load capacity lb (kg)	6,000/8,000 (2,722/3,629)	6,000/8,000 (2,722/3,629)
1.6	Load center LC in (mm)	Varies	Varies
1.7	Wheelbase WB in (mm)	See Table	See Table
Weight			
2.1	Weight, including battery 12-V Avg. (EW60 only)	1,490 (677)	N/A
2.2	Weight, including battery 24-V Avg.	1,940 (881)	2,090 (950)
Wheels & Tires			
3.1	Tires front/rear (R = Rubber, P = Poly; Front/Rear) (EW/EWR60)	R/P	R/P
3.2	Tires front/rear (R = Rubber, P = Poly; Front/Rear) (EW/EWR80)	P/P	P/P
3.3	Tire size, drive (front)	10 x 5 (254x127)	10 x 5 (254x127)
3.4	Tire size, load (rear)	3.25x6.375 (83x162)	3.25x6.375 (83x162)
3.5	Wheels, number front/rear	1/2	1/2
Dimensions			
4.1	Total length L4 in (mm)	See Table	See Table
4.2	Overall width W in (mm)	31.5 (800)	36.0 (914)
4.3	Outside fork spread W2	See Table	See Table
4.4	Overall truck height H6 in (mm)	59.5 (1,511)	59.5 (1,511)
4.5	Fork lift H in (mm)	6 (152)	6 (152)
4.6	Fork lowered height, tip/at battery box S in (mm)	3.25/3.50 (83/89)	3.25/3.50 (83/89)
4.7	Fork width W3 in (mm)	9 or 10 (229 or 254)	9 or 10 (229 or 254)
4.8	Fork length L3 in (mm)	See Table	See Table
4.9	Head length, 12-V/24-V L2 in (mm)	See Table	See Table
4.10	Skirt or bumper height H8 in (mm)	8.4 (214)	8.1 (206)
4.11	Skirt or bumper clearance H9 in (mm)	3 (75)	4.5 (114)
4.12	Turning radius TR in (mm)	See Table	See Table
Performance			
5.1	Travel speed, with/without load Avg.	2.6/3.5 (4.2/6.1)	5.75/8.0 (9.2/12.8)
5.2	Gradeability, with load 12-V (EW60 only)	10	N/A
5.3	Gradeability, with load 24-V (60/80)	10/5	10/5
Drive			
6.1	Steering: power, manual	Manual	Manual
6.2	Brake system, mechanical/hydraulic, electric	Mechanical	Mechanical
6.3	Battery Compartment, 12-V (EW60 only) BWxBL in (mm)	8.25x31.5 (210x800)	N/A
6.4	Battery Compartment, 24-V* BWxBL in (mm)	13.5x31.5 (343x800)	13.5x31.5 (343x800)
6.5	Voltage V	12 or 24 / 24	24
6.6	Amp hours, recommended	450 or 510	450 or 510
6.7	Battery weight (minimum 12-V/24-V) lb (kg)	450/900 (204/408)	N/A/1,130** (N/A/513)**
6.8	Drive motor, 60 min rating hp (kw)	1.3/3.6 (0.98/2.68)	3.6 (2.68)
6.9	Drive motor size (diameter) in (mm)	6.63 (168)	6.63 (168)
6.10	Pump motor size (diameter) in (mm)	4.3 (109)	4.3 (109)
6.11	Travel control (12-V/24-V)	PMC/SEM	SEM
6.12	Speed control	Infinitely Variable	Infinitely Variable

* Optional 9 in. battery compartment width available.

** 9 in. battery compartment minimum battery weight 600 lbs. (272 kg).

All values based on 48" forks.

External reinforcing bars are used on forks 72 in/1829 mm long or longer. The external reinforcing bars increase overall fork width to 23 in/584 mm or 28 in/711 mm and decrease the distance between forks 1 in/25 mm.

Travel speeds are average speeds and may vary by .5 mph.

EW60/80

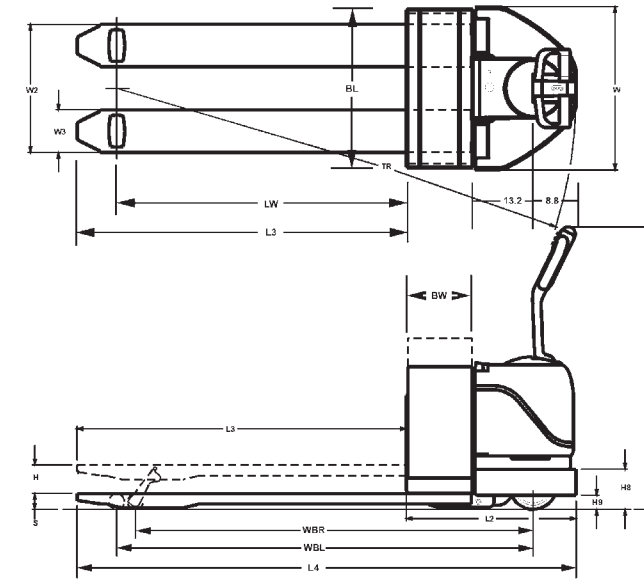

EWR60/80

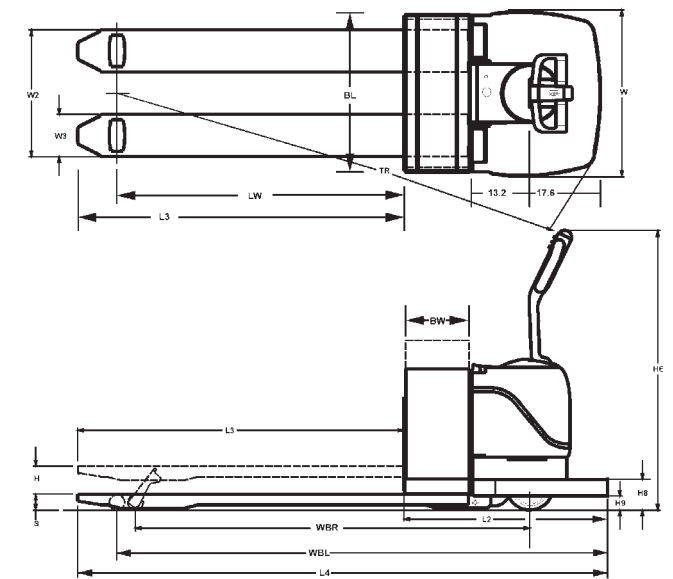

	EW60						EW/EWR60/80							
	12-Volts or 9" 24-V ^{1&2}						24-Volts							
Voltage	28.5	34.5	40.5	52.5	61.0	61.0	28.5	34.5	40.5	52.5	61.0	61.0		
LW Load Wheel ¹	(724)	(876)	(1,029)	(1,334)	(1,549)	(1,549)	(724)	(876)	(1,029)	(1,334)	(1,549)	(1,549)		
L2 Head Length ²	30.25 (768)						44.3 (1,125)							
L3 Fork Length ¹	36 (914)	42 (1,067)	48 (1,219)	60 (1,524)	84 (2,134)	96 (2,438)	36 ³ (914)	42 ³ (1,067)	48 (1,219)	60 (1,524)	84 (2,134)	96 (2,438)		
W2 Outside Fork Spread	22/27 (559/686)			23/28 (584/711)			22/27 (559/686)			23/28 (584/711)				
W3 Fork Width	9 (229)			10 (254)			9 (229)			10 (254)				
Overall Length	EW	66.9 (1,700)	72.9 (1,852)	78.9 (2,004)	90.9 (2,309)	114.9 (2,918)	126.9 (3,223)	EWR	72.2 (1,834)	78.2 (1,986)	84.2 (2,139)	96.2 (2,443)	120.2 (3,053)	132.2 (3,358)
WB Wheel Base	Raised	55.6 (1,412)	61.6 (1,565)	67.6 (1,717)	79.6 (2,022)	88.0 (2,235)	88.0 (2,235)	60.8 (1,544)	66.8 (1,697)	72.8 (1,849)	84.8 (2,154)	93.3 (2,370)	93.3 (2,370)	
	Lowered	59.4 (1,509)	65.4 (1,661)	71.4 (1,814)	83.4 (2,118)	91.8 (2,332)	91.8 (2,332)	64.6 (1,641)	70.6 (1,793)	76.6 (1,946)	88.6 (2,250)	97.1 (2,466)	97.1 (2,466)	
TR Turn Radius EW	Raised	64.4 (1,636)	70.4 (1,788)	76.4 (1,941)	88.4 (2,245)	96.8 (2,459)	96.8 (2,459)	69.6 (1,768)	75.6 (1,920)	81.6 (2,073)	93.6 (2,377)	102.1 (2,593)	102.1 (2,593)	
	Lowered	68.2 (1,732)	74.2 (1,885)	80.2 (2,037)	92.2 (2,342)	100.6 (2,555)	100.6 (2,555)	73.4 (1,864)	79.4 (2,017)	85.4 (2,169)	97.4 (2,474)	105.9 (2,690)	105.9 (2,690)	
TR Turn Radius EWR	Raised	-	-	-	-	-	-	77.0 (1,956)	83.0 (2,108)	89.0 (2,261)	104.0 (2,642)	109.5 (2,781)	109.5 (2,781)	
	Lowered	-	-	-	-	-	-	80.8 (2,052)	86.8 (2,205)	92.8 (2,357)	104.8 (2,662)	113.3 (2,878)	113.3 (2,878)	

¹ Subtract .75 in (19mm) for optional 9 in. 24-V battery compartment to 12-V values. ² Add .75 in (19mm) for optional 9 in. 24-V battery compartment to 12-V values.

³ SQR required for 8,000 lbs. trucks.

EW80 standard with 10" forks and 23" or 28" outside fork spread.

Wheelbase and Turning Radius on truck with 84 in/2,134 mm and 96 in/2,438 mm forks are indicated with load wheels located in the first opening of the second pallet (See B3 on pallet load wheel location chart).

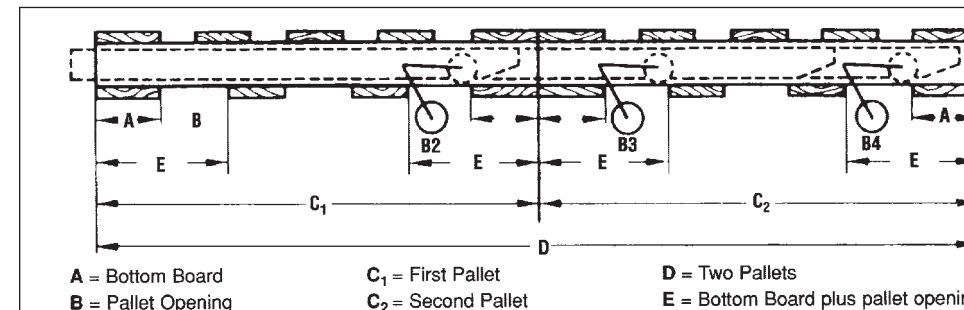

Pallet truck forks are normally the same length as a pallet. In one-pallet applications, the load wheels always function in the second pallet opening (see B2). When handling two pallets, the load wheels may operate in the first opening of the second pallet (see B3) or in the second pallet opening (see B4). When "C₁" and "C₂" dimensions or "D" dimensions equal the fork length, "E" is 14.5 in/368.8 mm minimum and "A" is 6 in/152 mm maximum.